

MAB 485

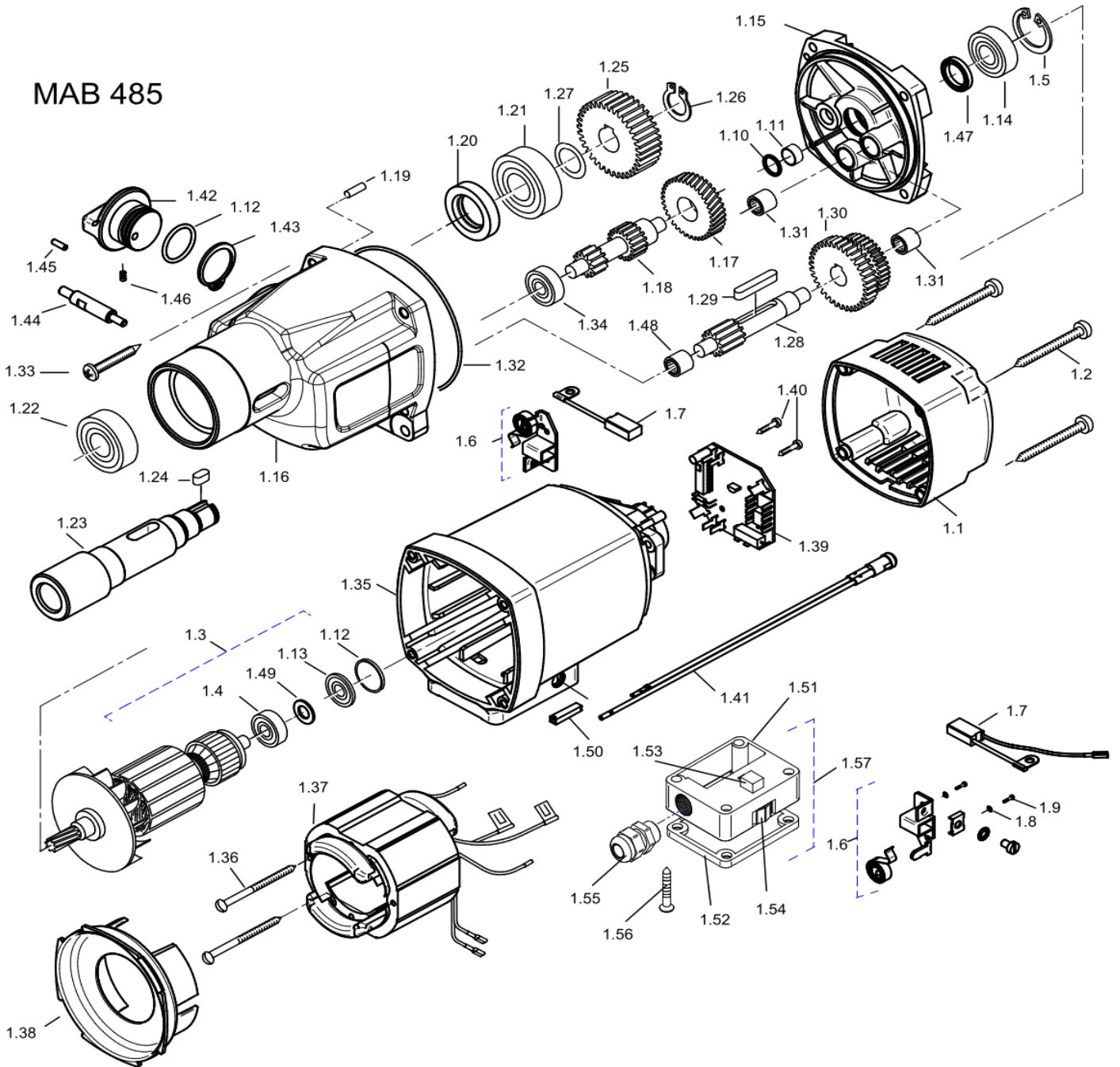

Pos. No.	Article no.	Description	pc
1.1	5010691	Cap for motor housing	1
1.2	5010581	Screw HC 4,8x45 DIN 7981	4
1.3.1.1	5013401	Armature 110V until June 2012	1
1.3.2.1	5015021	Armature 110V since June 2012	1
1.3.1.2	5013391	Armature 230V until June 2012	1
1.3.2.2	5013392	Armature 230V since June 2012	1
1.4	5010061	Ball bearing 608 2Z	1
1.5	5010271	Circlip ring 28/1,2 DIN 472	1
1.6.1	5010561	Carbon brush holder until June 2012	2
1.6.2	5010562	Carbon brush holder since June 2012	2
1.7.1.1	5010571	Carbon brush 6,3x10x18 for version 110V	2
1.7.2.1	5014011	Set of carbon brushes 6,3x12,5x18 for version 110V	1
1.7.1.2	5010572	Carbon brush 6,3x10x18 for version 230V	2
1.7.2.2	5010573	Set of carbon brushes 6,3x12,5x18 for version 230V	1
1.8	5013981	Corrugated spring washer B4 DIN 137	4
1.9	5013991	Self tapping screw ZM4x12	4
1.10	5012991	Circlip ring SW 10	1
1.11	5013411	Sealing sleeve	1
1.12	5010591	O-Ring 22x2,5	2
1.13	5010781	Ringmagnet	1
1.14	5012501	Ball bearing 6001 2RS	1
1.15	5013421	Gearbox bearing plate	1
1.16	5013431	Gearbox housing	1
1.17	5013441	Intermedium gear wheel 44 teeth	1
1.18	5013451	Shaft with 2 pinions 11/17 teeth	1
1.19	5010291	Pin M4x12 DIN 1474	1
1.20	5013461	Shaft seal 20x35x7	1
1.21	5010611	Ball bearing 6203 2RS	1
1.22	5011191	Ball bearing 6005 2RS	1
1.23	5013471	Spindle	1
1.24	5010751	Spring A5x5x12 DIN 6885	1
1.25	5010621	Spindle wheel 45 teeth	1
1.26	5010721	Circlip ring 15/1 DIN 471	1
1.27	5010531	Washer 15x22x0,2 DIN 988	1
1.28	5010411	Shaft for gear wheel 13 teeth	1
1.29	5010501	Spring A5x5x28 DIN 6885	1
1.30	5010631	Gear wheel assembly 34/40 teeth	1
1.31	5010351	Needle bearing HK 0810 DIN 625	1
1.32	5013481	O-Ring 85x1,78	1
1.33	5010221	Screw HC4,8 x 38 DIN 7981	4
1.34	5010071	Ball bearing 608	1
1.35.1	5010701	Motor housing complete until June 2012	1
1.35.2	5010702	Motor housing complete since June 2012	1
1.36	5010031	Screw HC 3,9 x 60 DIN 7981	2
1.37.1	5013501	Field coil 110V	1
1.37.2	5010821	Field coil 230V	1
1.38	5010641	Air conducting ring	1
1.39.1.1	5010851	Motor board 110 V	1
1.39.1.2	5010841	Motor board 230 V until February 2009	1
1.39.2.2	5010842	Motor board 230 V since February 2009 only together with potentiometer 100kOhm	1
1.40	5012771	Screw HC 2,9 x 13 DIN 7981	2
1.41	5015011	Control light for carbon brush	1
1.42	5013551	Gear change	1

<b>Pos. No.</b>	<b>Article no.</b>	<b>Description</b>	<b>pc</b>
1.43	5013561	Circlip ring 26/1,2 DIN 471	1
1.44	5013571	Bolt	1
1.45	5013581	Pin hardened 3m 6x10 DIN 6325	1
1.46	5013591	Locking bolt	1
1.47	5013601	Shaft seal KEIV 15x21x3	1
1.48	5014591	Needle Bearing DL 0810	1
1.49	5014731	Pressboard washer	1
1.50	5014741	Isolating grommet	1
1.51	5015031	Housing for potentiometer without potentiometer and hand wheel	1
1.52	5010891	Cover for housing of potentiometer	1
1.53.1	5010871	Potentiometer for speed control 250 kOhm	1
1.53.2	5011401	Potentiometer for speed control 100 kOhm 2V	1
1.54	5010861	Adjustment wheel blue for speed control 2V	1
1.55	6012131	Cable gland PG9	1
1.56	5014001	Chipboard screw 5x40 mm black chromated	4
1.57.1	5012511	Housing for potentiometer complete 250 kOhm	1
1.57.2	5012512	Housing for potentiometer complete 100 kOhm	1

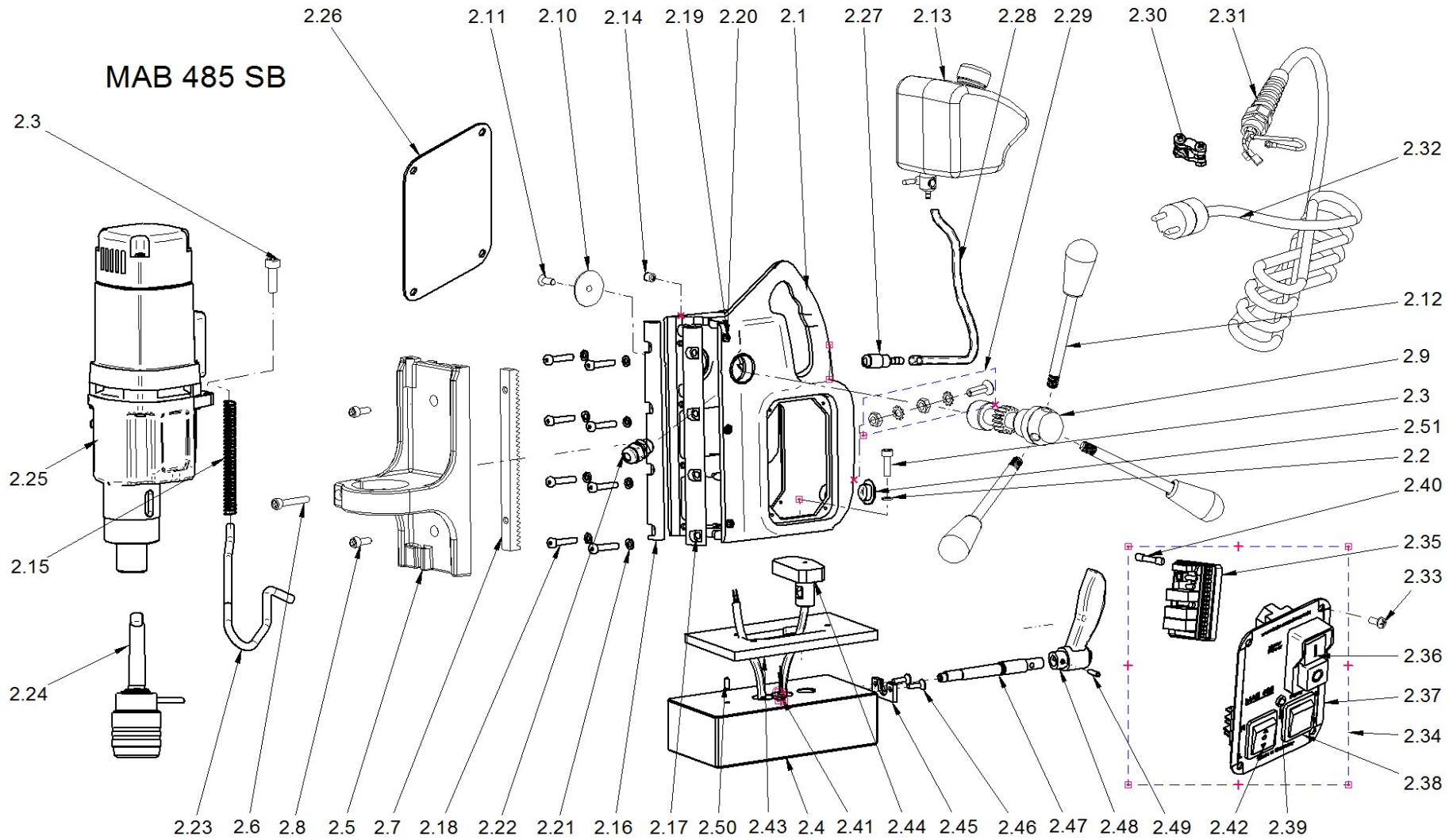

Pos. No.	Article no.	Description	pc
2.1.1	6012091	Housing for glued guide rails (both sides) until June 2009	1
2.1.2	6012093	Housing for screwed guide rails (both sides) since June 2009	1
2.2	6010021	Spring washer 6,1 DIN 7980	3
2.3	6010091	Hexagon socket M6x20 DIN 912	5
2.4	6014471	Magnet (electric) with indicator	1
2.5	6012101	Slide	1
2.6	6013171	Hexagon socket M6x35 DIN 912	1
2.7	6010081	Rack	1
2.8	6010011	Hexagon socket M6x16 DIN 912	2
2.9	6010211	Shaft for gear wheel	1
2.10	6010221	Washer for gear wheel 10,5x35x1,5	1
2.11	6010231	Screw M6x16 ISO 7047	1
2.12	6010242	Handle rod with knob	3
2.13	6012111	Coolant reservoir	1
2.14	4000121	Pressure piece	1
2.15	6012181	Spring for motor cable	1
2.16.1	6012701	Guide rail (1 set right/left) to be glued until June 2009	1
2.16.2	6012251	Adjustment rail left, screwed, 4 holes since June 2009	1
2.17.1	6014181	Guide rail right, screwed, 4 holes until June 2009	1
2.17.2	6012261	Adjustment rail right, screwed, 4 holes since June 2009	1
2.18	6050141	Hexagon socket M6x25 DIN 7984	8
2.19	6010031	Nut M5 DIN 934	3
2.20	6010041	Adjusting screw M5x16 DIN 913	3
2.21	6050151	Washer 6,4x11x1,6 DIN 433	8
2.22	6012131	Cable gland PG9	1
2.23	6012191	Motor cable 670mm	1
2.24	ZSS 200	Quick change drill chuck system Keyless CM2	1
2.25.1.1	5004861	Motor complete 110V until March 2012	1
2.25.2.1	5004862	Motor complete 110V since March 2012	1
2.25.1.2	5004851	Motor complete 230V until March 2012	1
2.25.2.2	5004852	Motor complete 230V since March 2012	1
2.26	7011831	Cover of housing, back side	1
2.27	ZSS 200K	Quick change coupling	1
2.28	ZSS 200S	Coolant tube blue, short 260mm	1
2.29	7010061	Earthing complete	1
2.30	4010291	Cord grip for connection cable	1
2.31	7010031	Mains cable gland PG 11	1
2.32.1.1	7010052	Connection cable 110 V with GB-plug	1
2.32.2.1	7010242	Connection cable 110V with US-plug	1
2.32.1.2	7010042	Connection cable 230V complete with plug	1
2.33	7010081	Screw M4x8 DIN 966	8
2.34.1	7011072	Switch plate complete with PC board 3 relais 110V	1
2.34.2	7011062	Switch plate complete with PC board 3 relais 230V	1
2.35.1	6012161	Control board with 3 relais 110V	1
2.35.2	6012152	Control Board with 3 Relais 230 V	1
2.36.1	7010931	Actuator 110 V	1
2.36.2	7010801	Actuator 230V	1
2.37	7014851	Switch plate front side	1
2.38	7010142	Magnet switch, 4 connection terminals	1
2.39	7010101	LED display for indicator red/green incl. cable and frame	1
2.40	7010131	Fuse 2A, 5x20	1
2.41	6012171	Indicator with cable	1
2.42	7010482	Rocker switch right/left	1

Pos. No.	Article no.	Description	pc
2.43	7014471	Ground plate	1
2.44	7014481	Pull-down adaptor	1
2.45	7014491	Stop plate	1
2.46	6013051	Screw with cross slot M4x12 DIN 966	2
2.47	7014501	Eccentric shaft	1
2.48	7010441	Clamp lever Gr.3 M10 black	1
2.49	6046161	Pin 4x16 DIN 6325	1
2.50	6046101	Pin 4x10 DIN 6325	1
2.51	7012181	PG 11 blank plug	1